



 **PORTAGANTRY**[®]
Load Bearing Pneumatic Castor Model

This product is patented

REIDLIFTING.COM

Our **PORTAGANTRY**® featuring load bearing Pneumatic Castors with air filled tyres offers a quality solution for customers that need to set up and locate their lifting solution on rough terrain, or on roof tops where a standard castor may otherwise cause damage to the surface material. Additionally, the gantry permits movement under load in many scenarios which is made possible by high quality directional locking castors and overall robust gantry design.

Key features

- Directional locking dual wheel castors with integrated brakes
- Tyres are air filled
- Integrated lifting points and wheel on the frames to support safe raise and lower of the gantry with mechanical advantage
- Integrated shackled cheek plates to enable safe load traversing along the beam
- Integrated ratchet raise and lower system for height adjustment
- Height adjustments at 100mm (4") increments
- Beam adjustment points to enable adjustment of the span to suit site conditions
- Ability to be able to interchange frames for maximum utilisation and freedom to achieve even the most challenging of lifting tasks

Configurations

The **PORTAGANTRY**™ featuring load bearing Pneumatic Castors is available in a range of configurations and can be customised in line with specific requirements (subject to WLL rating).

The **PORTAGANTRY**™ featuring load bearing Pneumatic Castors has the ability to be moved under load. (Subject to detailed instruction and supervision by a competent person).



**2000-3000KG
WLL**



**1-4 PERSON
ASSEMBLY**



**92-294KG
FLAT PACK**

Features & Performance

	2000	3000
Capacity		
Maximum Goods Lifting [kg]	2000	3000
Dimensions		
Minimum Height of Lift [mm]	2307	2307
Maximum Height of Lift [mm]	5916	5648
Minimum working Span [mm]	2090	2090
Maximum working Span [mm]	7370	7370
Trolley Options		
Standard	✓	✓
Gated	✓	✓
Close Coupled	✓	✓
Integrated Hoist	✓	×
Standard Features		
Ratchet Height Adjustment	✓	✓
Mechanical aid Assembly	✓	✓
Shackled cheek plate	✓	✓
Additional height adjustment	✓	✓
Finishes		
Anodised	✓	✓
316SS Fixings	Optional	Optional

The above features are incorporated in order to ensure maximum utilisation potential of this hybrid gantry solution and therefore maximise return on investment for the user. The gantry will not be rated as a fall protection product and is for material lifting only. For this reason castors cannot be retro-fitted to existing gantry frames.

- A** Beam length
- B** Beam adjustment
- C** Clear operating span
- D** Height to lifting eye
- E** Height increment
- F** Height to top of beam
- G** Width
- H** Height to top of roller

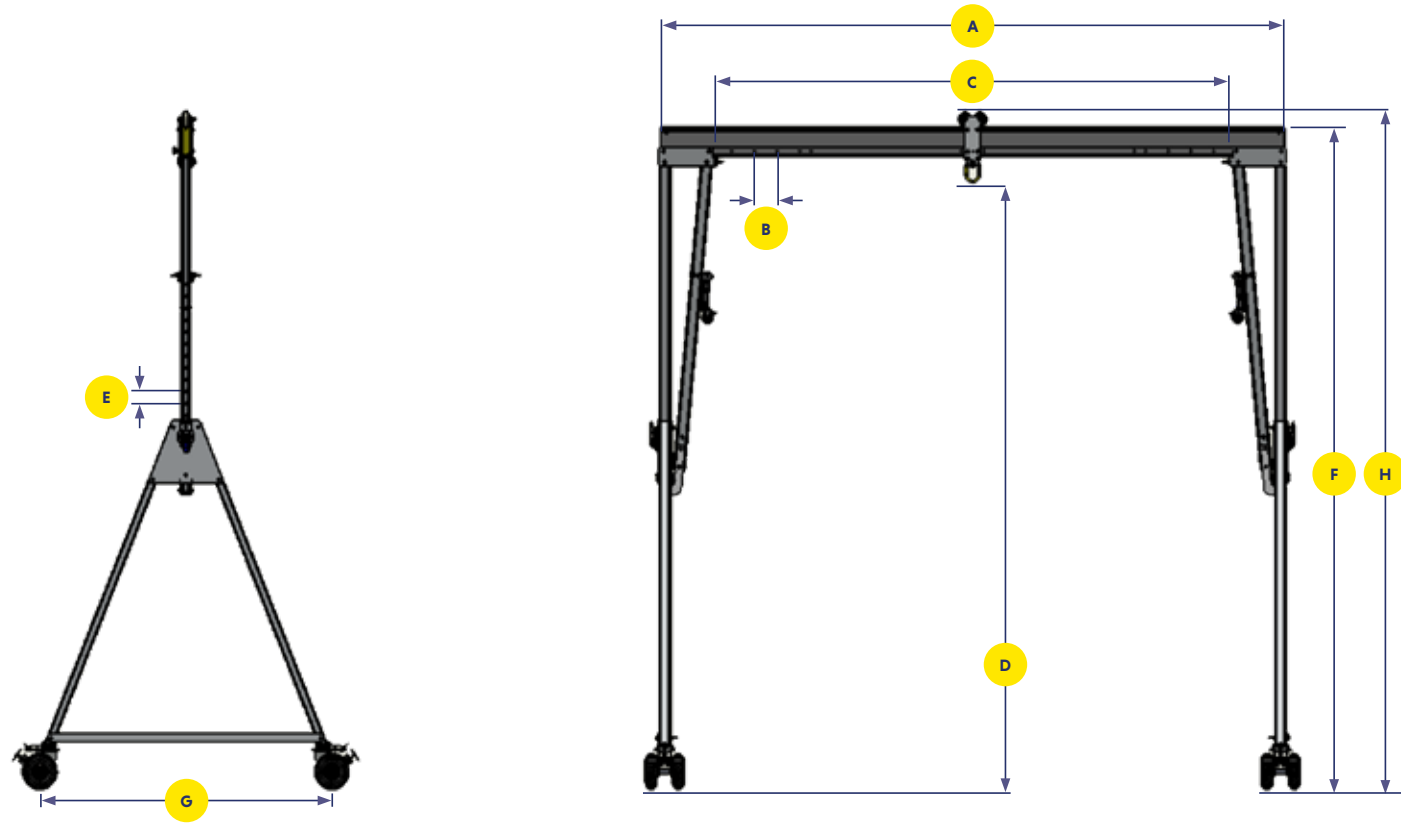

Standard Beam Length A (mm) (Clear Operating Span C = A - 1030 mm)

	3000	3920	4570	5500	6000	8400
A (mm)	3000	3920	4570	5500	6000	8400
C min (mm)	1570	2090	1940	2870	3370	5770
C max (mm)	1970	2890	3540	4470	4970	7370
2000	22	29	34	52	93	130
3000	22	37	43	85	93	130

Weight of Beams [kg]

*Clear operating span for D section beams is C = A - 1020mm.
To ensure stability of the structure, the operating span of the beam must be equal to or greater than the distance between the castors on the A-Frame.

Dimensions [mm]

Frame size [Product Code]	Dmax	E	Dmin	Fmax	Hmax	Hmin	G	A frame weight (KG)	Trolley roller size	Castor dimension
	Height to lifting eye	Height increment	Height to lifting eye	Height to top of the beam	Height to top of the roller	Height to top of the roller	Width			
PGAS02000I-PN	3307	10 x 100	2307	3637	3719	2719	2032	94	82	315
PGAS02000TC1-PN	5916	18 x 100	4116	6278	6360	4560	3027	146	82	315
PGAS02000TC3-PN	5113	12 x 100	3913	5476	5558	4358	2851	135	82	315
PGAS02000T-PN	4198	12 x 100	2998	4528	4610	3410	2317	100	82	315
PGAS03000I-PN	3307	12 x 100	2307	3637	3719	2719	2032	117	82	315
PGAS03000TC2-PN	5648	16 x 100	4048	5978	6060	4460	3027	141	82	315
PGAS03000TC3-PN	5113	12 x 100	3913	5476	5558	4358	2851	135	82	315
PGAS03000T-PN	4198	12 x 100	2998	4525	4607	3407	2315	129	82	315

Dimensions use standard Master Link Trolley, other options available to increase resulting height of lift (HoL) and to assist with load movement.

All information herein is copyright protected by REID Lifting Ltd. All company and product names are Trade Mark and Trade Name protected and all REID Product IPR is protected under Patents, Patents Pending and/or Design Rights.



Printed using environment friendly processes and materials.

REID Lifting

Unit 1 Wyview,
Newhouse Farm Ind. Estate
Chepstow, Monmouthshire
NP16 6UD UK

➤ +44 (0)1291 620 796
➤ enquiries@reidlifting.com
➤ www.reidlifting.com